



STATE OF CONSERVATION REPORT

Belize Barrier Reef Reserve System

(1996, Ref. 764)

BELIZE

43 COM



Index

State of Conservation Report

Belize Barrier Reef Reserve System - BELIZE

- A. State of Conservation Report (English)
- B. Annexes
 - 1. Draft TOR for the land survey study
 - 2. Land survey study proposal
 - 3. Draft contract for land survey study
 - 4. Draft amendments to EIA regulations



GOVERNMENT OF BELIZE

STATE PARTY REPORT

ON THE STATE OF CONSERVATION OF THE BELIZE BARRIER REEF RESERVE SYSTEM
(BELIZE) (N 764)

February 2019

WHC Decision 42 COM 7A.43

Forty-second Session.

Manama, Bahrain

June 24- July 4, 2018

Belize Barrier Reef Reserve System (Belize) (N 764)

The World Heritage Committee,

1. Having examined Document WHC/18/42.COM/7A.Add,
2. Recalling Decision **41 COM 7A.2**, adopted at its 41st session (Krakow, 2017),
3. Commends the State Party for the progress made in achieving the Desired state of conservation for the removal of the property from the List of World Heritage in Danger (DSOCR) and particularly welcomes the legal enactment of a moratorium on oil exploration and other petroleum operations in the entire maritime zone of Belize;
4. Considers that Indicators 2, 3 and 4 of the DSOCR have been fully achieved, and that Indicator 1 can be considered as achieved given the confirmation by the State Party that official verification of land tenure and subsequent declaration as mangrove reserves of the remaining public lands within marine reserves comprising the property has been officially agreed and initiated by the relevant ministries, and is expected to be completed in 2018;
5. Decides to remove Belize Barrier Reef Reserve System (Belize) from the List of World Heritage in Danger;
6. Requests the State Party to ensure that the process of official land tenure verification within the property is completed in due course and no later than by the end of 2018, and that the remaining public lands within the property are designated as strict reserves, in line with the commitment expressed by the State Party;
7. Urges the State Party to address the pending issues related to the revised regulatory instruments, in particular to ensure that specific provisions for consideration of potential impacts on the property's Outstanding Universal Value (OUV) are included in the Environmental Impact Assessment (EIA) Checklist for all types of projects, and that the ongoing revision of the EIA Regulations reflects this and is completed as a matter of priority;
8. Strongly encourages the State Party to continue to ensure that the resources required for the long-term implementation of the Integrated Coastal Zone Management Plan are secured;
9. Also requests the State Party to submit to the World Heritage Centre, by **1 February 2019**, an updated report on the state of conservation of the property and the implementation of the above, for examination by the World Heritage Committee at its 43rd session in 2019.

Executive Summary

The 2019 State of Conservation Report illustrates Belize's continued progress in maintaining the Belize Barrier Reef Reserve System (BBRRS). On June 26th, 2018 the World Heritage Committee decided to remove the BBRRS from the list of World Heritage in Danger for all the efforts and progress made by the people and country of Belize. For the year 2018-2019, Belize has continued to show progress in achieving Indicator 1 among other activities to maintain the Outstanding Universal Value of the Property.

In Decision 42 COM 7A.43, the WHC requested that the process of the official land tenure verification within the Property be completed in due course and no later than by the end of 2018, and that the remaining public lands within the property are designated as strict reserves. However due to funding issues, the process has been delayed and as a result will be completed in April 2019; the funding has now been secured and the TOR and contract has been drafted. In addition, consideration for the OUV of the property has also being integrated into the EIA regulations. Draft amendments has been completed and will be submitted to Cabinet in February 2019 for approval. Lastly, the Integrated Coastal Zone Management Plan (ICZMP) continues to be implemented through various activities, programmes and projects such as the Coastal Zone Advisory Committee, the coastal planning region inventory, the Resilient Reef Project, the Climate-Smart MPAs project and the Marine and Conservation Climate Adaptation Project (MCCAP). Additional efforts and progress has also been made on other current and new initiatives illustrating the country's efforts in maintaining the OUV of the property and in maintaining the status of the Belize Barrier Reef Reserve System.

INTRODUCTION

At the 42nd meeting of the World Heritage Committee held in Manama, Bahrain during the period June 24- July 4, 2018, it was decided to remove the Belize Barrier Reef Reserve System from the List of World Heritage Sites in Danger, which was originally listed in 2009 in Seville, Spain. Belize was commended for the progress made and for fulfilling most of the Desired State of Conservation save and except the completion of the official verification of land tenure and subsequent declaration for remaining public lands as mangrove reserves.

This report represents the State of Conservation of the Property for the year 2018-2019 and it includes the further advances and Belize's progress to address the recommendations of the World Heritage Committee upheld at the 42nd Session as well as the corrective measures stipulated in 2009. The report also includes the implementation and progress of the final indicator of the adopted Desired State of Conservation (DSOC).

The response to Decision **42 COM 7A.43** is now being presented for examination by the World Heritage Committee at its upcoming 43rd session in 2019.

Response from the State Party to the World Heritage Committee's Decision 2018

1. ***Commends the State Party for the progress made in achieving the Desired state of conservation for the removal of the property from the List of World Heritage in Danger (DSOCR) and particularly welcomes the legal enactment of a moratorium on oil exploration and other petroleum operations in the entire maritime zone of Belize;***
2. ***Considers that Indicators 2, 3 and 4 of the DSOCR have been fully achieved, and that Indicator 1 can be considered as achieved given the confirmation by the State Party that official verification of land tenure and subsequent declaration as mangrove reserves of the remaining public lands within marine reserves comprising the property has been officially agreed and initiated by the relevant ministries, and is expected to be completed in 2018;***
3. ***Decides to remove Belize Barrier Reef Reserve System (Belize) from the List of World Heritage in Danger;***
4. ***Requests the State Party to ensure that the process of official land tenure verification within the property is completed in due course and no later than by the end of 2018, and that the remaining public lands within the property are designated as strict reserves, in line with the commitment expressed by the State Party;***

The Government of Belize welcomes the commendations from the World Heritage Committee in achieving the Desired State of Conservation (**see Table 1**) and in making significant progress in achieving the corrective measures. The Government of Belize also welcomes the World Heritage Committee's decision in removing the Belize Barrier Reef Reserve System from the List of World Heritage in Danger in June 2018.

To fully achieve Indicator 1, Belize continues to work on the official verification of land tenure assessment. There has been a delay in meeting the December 2018 target due to difficulty in sourcing the needed funds (US \$50,000) to undertake the field study, however, those funds have been recently sourced (early January 2019) through the World Wildlife Fund. The new aim is to get the survey completed by mid-April while also requesting that the Ministry of Natural Resources simultaneously initiate actions on drafting the legal instrument to get the remaining public lands within the South Water Caye and Sapodilla Caye Marine Reserves designated as strict mangrove reserves. Once survey is completed, results can then be readily available to be integrated within the legal instrument to designate the reserves. (**See Annex 1, 2 & 3**).

5. ***Urges the State Party to address the pending issues related to the revised regulatory instruments, in particular to ensure that specific provisions for consideration of potential impacts on the property's Outstanding Universal Value (OUV) are included in the Environmental Impact Assessment (EIA) Checklist for all types of projects, and that the ongoing revision of the EIA Regulations reflects this and is completed as a matter of priority;***

Consideration for the Outstanding Universal Value (OUV) of the property has been integrated into the EIA Checklist as stated in the 2018 Desired State of Conservation, which has been operational since its amendment. The drafting of the necessary amendments to the EIA Regulations to give legal consideration to the OUV's in the EIA process has been completed recently and will be submitted to Cabinet in February 2019. Other provisions unrelated to the OUV process are included in the draft amendments and are still undergoing drafting - these have been blacked out in the **Annex 4** submitted. Once approved, it will be signed into law.

6. Strongly encourages the State Party to continue to ensure that the resources required for the long-term implementation of the Integrated Coastal Zone Management Plan are secured;

Since the effective date of the adoption of the ICZM Plan in February 2016, the Coastal Zone Management Authority and Institute (CZMAI) has been working to operationalize the plan as well as working closely with partners in implementing key recommendations. The following are a list of major accomplishments up to Dec 2018:

THE COASTAL ZONE MANAGEMENT (CZM) ADVISORY COUNCIL AND COASTAL ADVISORY COMMITTEES

- The CZM Advisory Council is a comprised of government agencies as well as civil society and private sector to advise the Coastal Zone Management Authority and Institute on technical and other related matters such as the implementation of the ICZM Plan.
- The CZM Advisory Council was re-instituted in June 2016 and has been convening quarterly meetings which serve as a coordination mechanism to share information with regard to coastal zone matters.
- Meetings have been held with representatives from local government who form a part of the Coastal Advisory Committees in coastal areas to introduce the Community Wardens Programme and the mechanism through which information will be received and relayed to enforcement agencies via the CZM Advisory Council.

IMPLEMENTATION OF SHORT-TERM ROAD MAP

- Consultations and meetings have been held with key partner agencies to advance the work on key activities outlined in the ICZM Plan.
- A draft MOU has been approved by the CZM Advisory Council to serve as a mechanism for partners to demonstrate their commitment to collaborate in the implementation of the ICZM Plan.

COASTAL PLANNING REGION INVENTORY

- The information collected will serve as a baseline for monitoring the implementation of the Belize ICZM Plan since the inventory includes the current status of land use (residential, commercial, industrial etc.) for parcels within the cayes and coastal areas.
- Drone mapping and data collection has been completed for a total of 52 cayes in three planning regions (Caye Caulker, South Northern and Belize Central); however, the 3 km buffer on land for south northern and Belize central regions are pending completion.
- CZMAI continues to implement a water quality monitoring programme to collect environmental data to be used as indicator for assessing risk in sensitive habitats.

FUNDING FOR IMPLEMENTATION OF ICZM PLAN

- The primary funding mechanism for the implementation of the ICZM Plan since 2016 has been the Marine Conservation and Climate Change Adaptation Project (MCCAP) financed by the Adaptation Fund. The objective of MCCAP is to implement a priority ecosystem-based marine conservation and climate adaptation measures to strengthen the climate resilience of the Belize Barrier Reef System and its productive marine resources.
- CZMAI recently entered into an agreement with the World Wildlife Fund financed by the Ministry of Environment of the Federal Republic of Germany (BMU) for the implementation of a five-year project entitled “Climate-Smarting Marine Protected Areas in the Meso-American Reef Region” which aims to strengthen adaptive capacity of coastal ecosystems and local communities. New information on climate risks to habitats and ecosystem services will be generated and mainstreamed into the ICZM Plan in order to better inform appropriate adaptation options for the coastal zone of Belize.
- CZMAI is also collaborating with agencies from the United Kingdom (UK) on specific projects including “Determining the resilience of marine based economies to environmental perturbations induced by land-use changes” under the Commonwealth Marine Economies (CME) Programme.

- Information being generated through these new projects will be included in the updating of the Belize Integrated Coastal Zone Management Plan (2016)- thus the outcomes will facilitate informed evidenced-based policy geared towards balancing trade-offs between different activities and services within the coastal zone, and conservation of the vital ecosystems services it provides.
- Other initiatives such as the Resilient Reefs Initiative which is a four-year, \$US9 million global effort to build the capacity of five World Heritage coral reef communities to respond to climate change will also provide direct support for implementation of key aspects of the ICZM Plan.
- A Communications and Engagement Strategy for CZMAI has also been developed and will assist in the socialization of the ICZM Plan and guidelines at the national level in an effort garner greater support for implementation.

Table 1 below shows the implementation progress of the DSOCR:

Indicators	Method of Verification	Timeframe	Progress
<p>I. The area of mangrove coverage in the property is maintained at least at the same level as when the property was inscribed on the List of World Heritage in Danger in 2009. There is no further loss of mangrove cover within the entire property, including all mangrove types that are unique and irreplaceable, measured against the 2009 baseline.</p>	<ul style="list-style-type: none"> ▪ Strengthening, adoption, implementation, and effective enforcement, of the currently proposed Mangrove Regulations ▪ Satellite imagery/aerial photography of the property indicating the current mangrove coverage, measured against the 2009 baseline ▪ Maps showing the distribution of the different categories of land ownership within the property and cadastral data of land tenure compared against the 2009 base year (the date when the site was inscribed on the List of World Heritage in Danger) ▪ Adoption by law of a permanent cessation of all sales and leases of state owned land throughout the property, measured against the 2009 baseline ▪ Adoption by law of a zoning plan covering the entire property that specifies clearly defined regulation for allowed development and use for each zone, based on scientific, ecological and biological information about the property's OUV and its attributes. 	<p>Completed by 31 December 2016</p>	<p>Revised Mangrove Regulations were adopted on June 23, 2018 by the Government of Belize.</p> <p>GEF-SGP project on mangrove coverage, measured against the 2009 baseline completed in 2018. The mangrove coverage is 95.3% of what it was in 1996 (year of inscription).</p> <p>The government maintains a voluntary moratorium on the sale of nationally held lands.</p> <p>Draft TOR and contract is complete for the land survey study. Due to funding issues, deadline has been pushed to April 2019 for completion of study. All remaining public lands will then be legislated into mangrove reserves.</p> <p>Adoption of Integrated Coastal Zone Management Plan in 2016. Area specific plans define what types of developments and standards are suitable for the various coastal areas.</p>
<p>II. No areas within the property and in its immediate vicinity are developed in ways that affect the property's natural outstanding beauty and status as a</p>	<ul style="list-style-type: none"> ▪ Adoption by law, implementation and adequate enforcement regulations that specify the type, scale and density of coastal development consistent with the requirements to maintain the property's natural outstanding beauty and that of its immediate surroundings, including 	<p>Completed by 31 December 2016</p>	<p>The drafting of necessary amendments to the EIA regulations to give effect and consideration to the OUV's has been completed. These will be submitted to Cabinet in February 2019.</p>

<p>globally significant natural phenomenon of Outstanding Universal Value</p>	<p>establishment of areas where no development should be permitted</p>		<p>Drafting of the amendments to the EIA regulations is complete and will be submitted to Cabinet in Feb. 2019.</p> <p>Area specific development guidelines were developed under the ICZMP</p> <p>Mangrove regulations provide special protection/stricter measures to mangroves in "Priority Mangrove Areas".</p>
<p>All areas within the property and the surrounding areas that support the ecological functioning of the system are excluded from oil exploration and exploitation</p>	<ul style="list-style-type: none"> ▪ A map that defines, on the basis of oceanographic, ecological and other scientific information, the property's surrounding areas where no oil exploration and exploitation can be permitted ▪ Legal adoption of a permanent exclusion of the entire property and the defined surrounding areas from oil exploration and exploitation 	<p>Completed by 31 January 2016</p>	<p>The Parliament of Belize approved the Petroleum Operations (Maritime Zone Moratorium) Act No. 54 of 2017 in December 2017, which states that all oil exploration and exploitation is now prohibited in the entire maritime zone of Belize.</p>
<p>The property is managed effectively and in an integrated way that will ensure the protection of its Outstanding Universal Value, and appropriately allows for achieving both sustainable socio-economic and environmental goals</p>	<ul style="list-style-type: none"> ▪ Adoption, implementation and effective enforcement of the Integrated Coastal Zone Management Plan, reflecting the World Heritage status of the property and its conservation and sustainable use requirements and consistent with the plan's draft version of January 2015 	<p>Completed by 31 December 2016</p>	<p>ICZM plan approved on Feb. 9th, 2016.</p> <p>The ICZM plan is being implemented through funding under the Marine Conservation and Climate Adaptation Project (MCCAP).</p> <p>Area specific development guidelines were developed under the ICZMP</p>

Updates on other conservation initiatives/issues identified by State Party

- I. The draft Fisheries Resources Bill has been re-submitted to the Attorney General's Ministry for the final legal review. The Task Force made final inputs to the document prior to making the re-submission in September 2018 to the Attorney General's Ministry. It is anticipated that the final document will be submitted to Cabinet and subsequent approval by the House of Representatives by mid-2019.

- II. As stated in the 2018 State of Conservation Report, the "National Replenishment Zone Expansion" initiative continues to be implemented along with its NGO and private sector partners. The project seeks to increase the current functional 'NO TAKE' areas in Belize from the current 3.15% (58,699.4 ha) to 10% (186,541.7 ha) of the territorial seas taking into consideration both near shore and deep sea areas deemed critical for the overall ecosystems functioning of Belize's coastal systems and safeguarding of marine biodiversity. The consultant, who was hired, has submitted his final report and maps illustrating the revised zones which were ground truthed with the aid of the key stakeholders including but not limited to: the Fisheries Department, the Forest Department, Lands and Survey Department and the University of Belize. Currently, the Land Information Centre (Ministry of Natural Resources) has received the consultant's legal description of the zones. The finalization of the description of the coordinates is being completed and it is expected that this matter will be submitted to the Cabinet in February 2019.

- III. In maintaining and improving the management the Belize Barrier Reef Reserve System, some of the sites have been updating/developing management plans. In 2018, the management plan for the South Water Caye Marine Reserve has been updated and approved by the Fisheries Department. A draft management plan for the Glover's Reef Marine Reserve is currently being developed and it is also envisioned that an updated management plan for the Bacalar Chico Marine Reserve will be developed in 2019/2020. These management plan will include amendments and improvements to reflect more detailed development guidelines such as the Integrated Coastal Zone Management Plan and take on board the recommendations from Advisory committees as it relates to activities within these protected areas.

- IV. The 2016-2021 National Lionfish Management Strategy, a national initiative for the long-term control of the Lionfish population (*Pterois spp.*) has been approved by the Fisheries Department. The management strategy which addresses mechanisms to manage the lionfish population will be launched in February 2019.

Measures/Efforts to maintain and improve OUV of the Property

- I. The following is an update on some of the voluntary commitments under SDG 14. In June 2017, a Belize Delegation, including the Minister responsible for Fisheries, participated in the UN Ocean Conference and presented its voluntary commitments to “conserve and sustainable use the oceans, seas and marine resources for sustainable development”.
- By 2018, enact and implement the new Fisheries Bill;
 - The Fisheries Bill has been resubmitted to the Attorney General’s Ministry in September 2018 and will be passed by mid-2019.
 - Promote the implementation of FAO Voluntary Guidelines for Securing Sustainable Small-scale fisheries;
 - The Fisheries Department has and continues to promote the FAO Voluntary Guidelines for Securing Small-scale fisheries which support responsible fisheries, sustainable social and economic development and promote a human rights-based approach. These guidelines have been integrated into the development of manage access and the draft Fisheries Bill.
 - By 2020, adopt the “Fish right, Eat right” certification program;
 - The “Fish right, Eat right” certification program commenced in 2018 in order “to curb illegal fishing and promote best practices in fisheries by providing marketing incentives throughout the supply chain via the promotion of responsible seafood consumption.” This is in collaboration with the Fisheries Department, Wildlife Conservation Society, Oceana, Belize Tourism Board, Belize Tourism Industry Association, Belize Federation of Fishers and Environmental Defense Fund. Up to date more than 37 restaurants have voluntarily signed on to the program.

Belize Barrier Reef Reserve System (Belize) (N 764)

- By 2020, implement best practices for sustainable seaweed aquaculture as supplemental income for fishers that include smart sighting, sustainability standards and provides ecosystem services that is incorporated into a policy framework for Belize;
 - The Fisheries Department in collaboration with The Nature Conservancy, Turneffe Atoll Sustainability Association and some fishers have begun developing best practices for sustainable seaweed aquaculture.
 - By 2020, establish sustainable catch limits for the Caribbean Spiny Lobster;
 - Catch limits for Caribbean Spiny Lobster are being considered by the Fisheries Department for the 2019 open lobster season.
 - By 2020, develop and implement the National Fisheries Policy;
 - The National Fisheries Policy is currently being drafted by a consultant for the Fisheries Department.
 - By 2020, develop and implement fisheries management plan and adaptive management plans for main commercial species such as conch , lobster and fin fish; and
 - Management plans for conch and lobster has been updated using the adaptive management framework.
 - By 2021, achieve the full implementation of the Integrated Coastal Zone Management Plan by Government agencies, developers and relevant stakeholders.
 - Few initiatives and changes in legislations (i.e. newly passed Mangrove regulations) have implemented the ICZMP (see above mentioned section on ICZMP).
- II. Coral restoration efforts continue to occur in the waters of Belize since its inception nine years ago especially within two BBRRS sites: the Laughing Bird Caye National Park and South Water Caye Marine Reserve. Up to the end of 2018, Fragments of Hope Ltd. has more than 23 nurseries and has outplanted more than 122,000 corals. Within the Laughing Bird Caye National Park, there is five nurseries and a grand total of 80,974 outplanted corals. The efforts within the South Water Caye Marine Reserve initiated a couple years ago and already has 6 coral nurseries and a total of 6,923 of outplanted corals. Many of the sites have >30% coral cover; coral cover increased from 6% in 2010 to >40 in 2015 for some sites. Fragments of Hope train about 12 Belizeans a year on coral restoration

and participate in a number of knowledge exchange forums/missions: REEF Futures (Florida; Dec 2018); GCFI (San Andrés, Colombia Nov 2018); HRI partner meeting (Caye Caulker Oct 2018); Jamaica/Belize exchange trip (GEF-SGP March/May 2018) and Mexico exchange with scientists (Sept 2018). The LBCNP has been declared the Best example of reef restoration in the Caribbean by all experts.

- III. An important aspect of achieving and maintaining the desired state of conservation of the Belize Barrier Reef System World Heritage Site (WHS) is ensuring the effective branding of the system and improved national and international awareness of Belize's reef and conservation success. Along these lines, the Government of Belize, through its relevant Ministries and Departments/Agencies including the office of the UNESCO Secretary General; the Ministry of Agriculture, Forestry, Fisheries, Environment and Sustainable Development, the Ministry of Natural Resources, and the Ministry of Tourism and Civil Aviation, intends to work collaboratively with the Belize Marine Fund (BMF), World Wildlife Fund (WWF)—members of the Belize World Heritage Advisory Committee—and other Civil Society Organizations to embark on a national/international branding and marketing campaign, and branding strategy to promote Belize's Reef. In October 2018, the Office of the UNESCO Secretary General had initial discussions with representatives of the Ministry of Tourism, WWF and the BMF around marketing and branding efforts for the Belize Barrier Reef System World Heritage Site. The BMF has expressed its willingness to co-finance the initiative. It is envisioned that the Office of the UNESCO Secretary General will be able to move forward collaboratively with the partners outlined for tangible outputs towards the development of a national/international branding and marketing campaign, and branding strategy for the Belize Barrier Reef System WHS by the end of 2019.

Conclusion

In conclusion, this report reiterates the commitment in maintaining the inscription of the Belize Barrier Reef Reserve System as a World Heritage Site as the country of Belize continues to make efforts in conserving our natural habitats for present and future generations.

ANNEXES

- Annex 1: Draft TOR for the land survey study
- Annex 2: Land survey study proposal
- Annex 3: Draft contract for land survey study
- Annex 4: Draft amendments to EIA regulations



WWF Mesoamerica Terms of Reference / Statement of Work

1. Project Title:

Survey of National Lands within South Water Caye and Sapodilla Caye Marine Reserves: Towards Safeguarding their OUV through Strick Designation as Mangrove Reserves

2. Executing Individual (Individual's Capabilities and Brief Overview):

Mr. Henry Alexis Fairweather is a licensed land surveyor with greater than thirty years of experience. He has practiced survey engineering and more particularly, land surveying in Belize and Saudi Arabia. Mr. Fairweather holds a Bachelor of Science Degree in Engineering from University of New Brunswick, Canada and is a license land surveyor in Belize since 1996.

Mr. Fairweather was the Principal Land Survey within the Belize Ministry of Natural Resources from 2008 to 2009. He has considerable experience a) supervising field personnel undertaking land surveys, b) in the production of engineering maps from field data (e.g. subdivision surveys), and 3) in execution of inshore hydrographic surveys and charts production. He has prepared and taught survey mathematics to various survey technicians, including the use of survey instruments for measuring angles and distances. Mr. Fairweather has led many forms of surveys within Belize and internationally, including:

- Cadastral surveys: subdivision design and surveys, including for the Belize's Jaguar Corridor
- Engineering: topographic, roads and site surveys
- Carried out boundary survey for Sarstoon-Temash Forest Reserve and Payne's Creek National Park
- Computed digital elevation model (computed DEM in Excel sheet)

Mr. Fairweather is very familiar with the institutional processes and issues associated with land surveys in Belize.

3. Project Background (history, purpose, focus):

The Belize Barrier Reef Reserve System World Heritage Site comprises the Bacalar Chico National Park and Marine Reserve, Blue Hole Natural Monument, Half Moon Caye Natural Monument, South Water Caye Marine Reserve, Glovers Reef Marine Reserve, Laughing Bird Caye National Park, and Sapodilla Cayes Marine Reserve. The Government of Belize and the World Wildlife Fund (WWF) recognize the ecological and economic value of the Belize Barrier Reef Reserve System as a marine ecosystem of biodiversity and geo-physical significance for present and future generations of Belizeans as well as its contribution as a UNESCO World Heritage Site (WHS). The Government of Belize is desirous of designating areas of national land that may remain within South Water Caye and Sapodilla Caye Marine Reserve as strict reserves in furtherance of the WHS. The areas of national lands within the two marine reserves, however, are not fully known.

Belize's Ministry of Natural Resources and Ministry of Forestry, Fisheries, the Environment and Sustainable Development entered into a Memorandum of Understanding with the World Wildlife Fund (WWF) to survey the remaining areas of national land within the South Water Caye and Sapodilla Caye Marine Reserves to declare them as strict mangrove reserve to maintaining the Outstanding Universal Values (OUV) of the Belize Barrier Reef Reserve System World Heritage Site.

With financial support from WWF, an expert licensed surveyor in the name of Mr. Henry Alexis Fairweather, is being hired to undertake the survey. Mr. Fairweather is tasked with determining the availability of national lands within the South Water Caye and Sapodilla Caye Marine Reserves through registry research and on-ground assessment. All public lands comprising individual and separate parcels scattered across the South Water Caye Range and Sapodilla Caye Range that have substantial mangrove coverage will be surveyed.

The survey work, from signing of the contract to the final drawing and reporting to the Commissioner of Lands' office, WWF and Ministry of Forestry, Fisheries, the Environment and Sustainable Development should take no longer than 2 months and 3 weeks. Any work sub-contracted to any individual(s) by Mr. Fairweather remains the sole responsibility of Mr. Fairweather, and should this occur, the consultant shall be responsible for all the anticipated deliverables. Mr Fairweather is expected to also work closely with the Land Department's Principal Surveyor, abide by surveyor's code of conduct, and other surveyor's guidelines and regulations applicable within the country of Belize.

Both major and minor markers will be used to survey and locate keys. More detailed description and method of the survey work to be undertaken is described in Attachment #1 (Proposal for Survey – South Water Caye and Sapodilla Caye Marine Reserve).

The total project cost is US\$46,500.

4. General Project Objective:

To designate strict protection status of national lands within marine reserves that makes up the Belize Barrier Reef Reserve System World Heritage Site.

5. Specific Objectives:

- 1) Determine available national lands within the South Water Caye and Sapodilla Caye Marine Reserves by field inspection and appropriate land survey methods.
- 2) Survey unsurveyed lands within the reserves in areas of substantial mangrove coverage.

6. Project Logframe

Specific Objectives	Activities	Deliverables	Results
Objective 1: Determine available national lands within the South Water Caye and Sapodilla Caye Marine Reserves by registry research, exchanges with Land Department, field inspection and other appropriate land survey methods.	1. Carry out meeting(s) with the Ministry of Natural Resources' Principal Land Surveyor to obtain inputs and guidance to carry out the survey.	Synopsis of meeting Draft cadastral database of known national lands (from baseline registry research)	Information to guide the land survey initiative is available
	2. Undertake research of land registry to determine potential national lands within the reserves.	Survey plan	
	3. Generate database on findings to share with the Belize Government and WWF.		
	4. Prepare survey plan, and schedule field surveys and any needed ground-truthing in		

	collaboration with Principal Surveyor and Belize Fisheries Department (for research permit).		
Objective 2: Survey unsurveyed national lands within the two reserves in areas of substantial mangrove coverage.	1. Undertake field surveys of national lands with mangrove cover in the South Water Caye and Sapodilla Caye Marine Reserves.	Survey report with full description of process, methods and approach taken, and findings	Survey outputs available to inform designation of strict mangrove reserves within South Water Caye and Sapodilla Caye Marine Reserves
	2. Prepare report on method, process, approach and findings	Cadastral maps both in hardcopy and CAD format	
	3. Prepare and submit cadastral maps (hard copy and CAD format)	Compilation map of surveys in hardcopy and CAD format	
	4. Prepare and submit field notes	Field notes	

7. Activity Plan + (Activity Timeline):

Activities	Months		
	1	2	3
Objective 1: Determine available national lands within the South Water Caye and Sapodilla Caye Marine Reserves by registry research, exchanges with Land Department, field inspection and other appropriate land survey methods.			
1. Carry out meeting(s) with the Ministry of Natural Resources' Principal Land Surveyor to obtain inputs and guidance to carry out the survey.	X		
2. Undertake research of land registry to determine potential national lands within the reserves.	X		
3. Generate database on findings to share with the Belize Government and WWF.	X		
4. Prepare survey plan, and schedule field surveys and any needed ground-truthing in collaboration with Principal Surveyor and Belize Fisheries Department (for research permit).	X	X	
Objective 2: Survey unsurveyed national lands within the two reserves in areas of substantial mangrove coverage.			
1. Undertake field surveys of national lands with mangrove cover in the South Water Caye and Sapodilla Caye Marine Reserves.	X	X	X
2. Prepare report on method, process, approach and findings		X	X
3. Prepare and submit cadastral maps (hard copy and CAD format)		X	X
4. Prepare and submit field notes			X

8. Monitoring and Evaluation Plan:

No.	Product	Deliverable Date	Payment (US\$)

1.	Draft cadastral database of known national lands (from baseline registry research)	02/10/19	20,000
2	Synopsis of meetings with Lands Department	02/15/19	10,000
3	Survey plan	02/15/19	10,000
2.	Survey report with full description of process, methods and approach taken, and findings	04/19/19	2,500
3.	Cadastral maps both in hardcopy and CAD format	04/19/19	2,500
4.	Compilation map of surveys in hardcopy and CAD format	04/22/19	1,000
5.	Field notes	04/22/19	
6.	Expense Report	04/30/19	500

9. Expected Results:

- Information to guide the land survey initiative within South Water Caye and Sapodilla Caye Marine Reserves is available
- Survey outputs available to inform designation of strict mangrove reserves within South Water Caye and Sapodilla Caye Marine Reserves

10. Budget: (taxes included)

No.	Budget Line	Quantity	Unit	Unit Amount	Total Amount US\$
	<u>Consultant Fees:</u>				
1	Fees (Lead Surveyor and team)	1	1	37,000	\$ 37,000.00
2		0		0	
3		0		0	
	Total Consultant Fees:				\$ 37,000.00
	<u>Expenses</u>				
1	Boat rental	10	600	6,000	\$ 6,000.00
2	Accommodation/camping gear	6	500	3,000	\$ 3,000.00
3	Field supplies - survey markers	1	1	500	\$ 500.00
					\$ 9,500.00
1		0		0	\$ -
2		0		0	\$ -
3		0		0	\$ -
					\$ -
					\$ 9,500.00
	Total				\$ 46,500.00

AGREEMENT INFORMATION FORM (AIF)

I. Consultant Information (business/company):

a. Consultant: (business/company):	
Legal Name and Address of Consultant:	Henry Alexis Fairweather Bradly Street, Santa Elena Town Cayo District, Belize
b. Authorized Signatory: (only for companies)	
Name:	Henry Alexis Fairweather
Position:	Licensed Surveyor
c. Technical Contact: (only for companies)	
Name:	Henry Alexis Fairweather
Position:	License Surveyor
Telephone:	601-9145
E-mail:	halexisf@gmail.com
d. Financial/Administrative Contact: (only for companies)	
Name:	
Position:	
E-mail:	

II. WWF Agreement Technical Information

WWF Technical Officer:	Nadia Bood	
WWF to be copied:		
Global Goal/Theme:	Our most important fisheries and ocean ecosystems are productive and resilient and improve livelihoods and biodiversity.	
Project Title:	Survey of National Lands within South Water Caye and Sapodilla Caye Marine Reserves: Towards Safeguarding their OUV through Strick Designation as Mangrove Reserves	
Agreement Term: Start Date:	January 29 th , 2019	
End Date:	April 30 th , 2019	
Indicate whether the Consultant Technical Lead is key to WWF doing business with this company/business:	<input checked="" type="checkbox"/> Yes	<input type="checkbox"/> No
Primary Donor Name/ Agreement No. / Funding Source:	WWF Int/ WHS Protection PO2177	

Yes/No

a. Is the Consultant currently under contract with WWF that you are aware of?	No
b. Is the Consultant a government employee?	No
c. Is the Consultant a former WWF-US employee?	No
d. Is the Consultant an employee of any WWF?	No
e. Is there any lobbying to be conducted as part of the scope of the agreement?	No
g. FIELD – If individual consultant is a US taxpayer, contact your PA at HQ	No

Program Budget Information:

Fiscal Year	GL Code	Dept. Number	Project Number	Funding Source	Amount US\$
FY 19	2206	626	10003436	8124	\$46,500
Total:					\$ 46,500
A. Are these funds in the approved budget for this activity?				<input checked="" type="checkbox"/> Yes <input type="checkbox"/> No	
B. Have these funds been received by WWF?				<input checked="" type="checkbox"/> Yes <input type="checkbox"/> No	

**PROPOSAL FOR SURVEY OF NATIONAL LANDS WITHIN THE
SOUTH WATER CAYE AND SAPODILLA CAYE MARINE RESERVES**

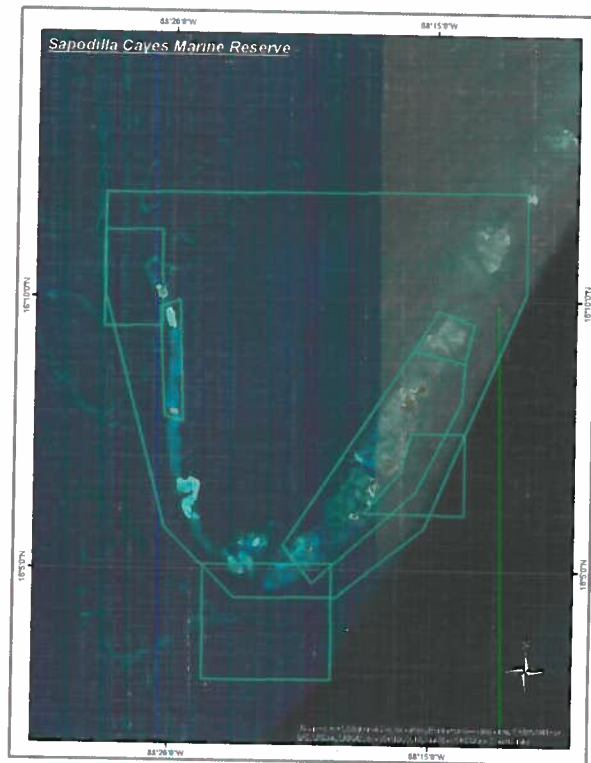
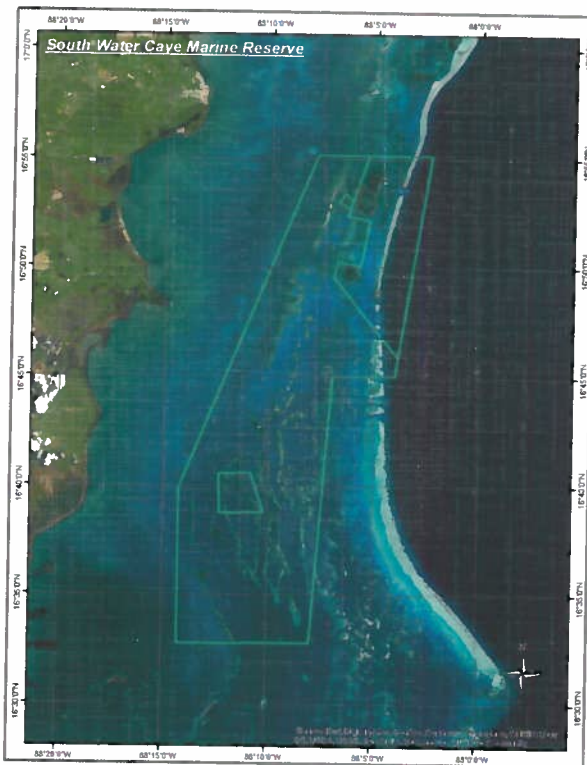
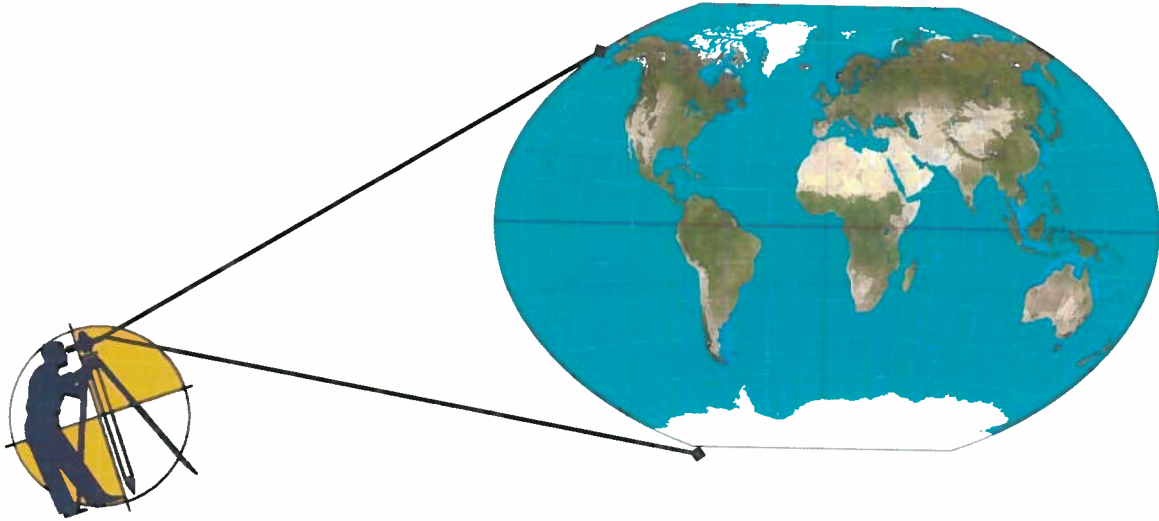

***Prepared by:- H.A. Fairweather B.Sc.
Licensed Land Surveyor Belize
Surveying Engineering (UNB Canada)***

PROPOSAL FOR SURVEY OF NATIONAL LANDS WITHIN THE SOUTH WATER AND SAPODILLA CAYES

MARINE RESERVES

CONSULTANT

- 1.1 I am offering my expertise and many years of practical experience relevant to the services you require. I have practiced Surveying Engineering and more particularly, Land Surveying in Belize also Saudi Arabia. Please see attached Resume.

SCOPE OF WORKS

- 1.2 Determine available national lands within the South Water Caye and Sapodilla Caye Marine Reserves by field inspection and appropriate Land Survey methods.
- 1.3 Survey, un-surveyed Lands in the reserves in areas of substantial mangrove coverage.

METHODOLOGY

- 1.4 Both major and minor markers will be used to survey and locate the cayes.

The axis of a caye will be defined by two major markers and surveyed in World Geodetic System Datum (ITRF94), these values are then converted to North American Datum 27 (NAD27 Belize).

Between the major markers will be set minor markers sufficient in numbers to coordinate the shape of the caye. Please see diagram.

Major markers are designated M1 and M1A. Minor markers are designated M1-1, M1-2...M1-X per caye. The cayes will be numbered M1, M2...MX and other major points M1A and M1B and so on, where the shape and size of the caye require greater definition. This method of numbering will be carried forward seamlessly from South Water Caye Reserve into Sapodilla range of cayes in the Sapodilla Reserve.

CALIBRATION

- 1.5 Calibration of data of task already done are not pertinent to the jobs at hand. The correct procedure is the following;

Conduct calibration exercise a day before the commencement of the survey task and again at the completion of the first phase of the survey, (phase 1 being South Water Caye) and a third exercise at the end of the second phase (phase 2 being Sapodilla Cayes). In this way the work done is bracketed by calibration exercises. These exercises will be submitted as part of the Deliverables under Survey Report.

1.6 SOUTH WATER CAYE RESERVE

Field Survey

The reserve has an estimated 82 un-surveyed cayes. Our research found One hundred and thirty-two survey Entries (132) indicating that some Islands have been subdivided.

We expect that some islands are still in the inventory of National Lands. Regrettably it can only be ascertained by Field Surveys.

To carry out this Field exercise requires the following:

Equipment

- 1 Boat with engine
- 2 GPS units
- 3 Survey Markers (we estimate that approximately 206 (+-) major and 752 (+-) minor markers will be used. These markers will be constructed of 2 ½ and 4 inch PVC pipe filled with concrete with steel center rod with length between 4 and 5 feet-see attached diagram).
- 4 Accommodation & Camping Gear

Survey Instruments to be used

The survey team will be equipped with the following survey instruments;

Total Station	1 Top Con Brand 1 Sokisha Brand
GPS	1 Pair Leica double frequency, within 3cm (+/-) Horizontal, with software with capability for Point Positioning and RTK

Personnel

The Field Survey will be carried out by Three (3) Teams as detailed below;

Team 1	Survey Technician & Overall Supervisor– Dean Williams
	1 Survey Captain - Nazim Berjes
	1 Chain Saw Worker - Miguel Mendez
	2 Field Workers - Javier Manzanero Luis Jimenez
Team 2	1 Survey Technician - Walter Calix
	1 Survey Captain - Samuel Garcia

	1	Chain Saw Worker -	Gian Landero
	3	Field Workers -	Miguel Escobar Cesar Hob
Team 3	1	Survey Technician -	Jose Luis Cunil
	1	Survey Captain -	Isais Mendez
	1	Chain Saw Expert -	Ronai Montero
	2	Field Workers -	Lucas Mendez Luis Frutos
	1	Cook (to serve all 3 teams) -	Domingo Martinez

Total Estimated Cost of Survey South Water Caye **\$60,000.00**

1.7 **SAPODILLA CAYE RESERVE SURVEY**

Field Survey

This reserve has an estimated 10 un-surveyed cayes. Our research found twelve (12) survey Entries indicating that some Islands have been subdivided.

We expect that some islands are still in the inventory of National Lands. Regrettably it can only be ascertained by Field Surveys.

Nevertheless, Hunting Caye with 'Light House' remain in the National Inventory. Other cayes, not yet identified must be determined by inspection.

To carry out this Field exercise requires the following:

Equipment

- 1 Boat with engine
- 2 GPS units
- 3 Survey Markers (we estimate that approximately 206 (+-) major and 752 (+-) minor markers will be used. These markers will be constructed of 2 ½ and 4 inch PVC pipe filled with concrete with steel center rod with length between 4 and 5 feet-see attached diagram).
- 4 Accommodation & Camping Gear

Survey Instruments to be used

The survey team will be equipped with the following survey instruments;

- | | |
|---------------|--|
| Total Station | 1 Top Can Brand |
| | 1 Sokisha Brand |
| GPS | 1 Pair Leica double frequency, within 3cm (+-) Horizontal, with software with capability for point positioning and RTK |

Personnel

The Field Survey will be carried out by Three (3) Teams as detailed below;

- | | |
|--------|---|
| Team 1 | Survey Technician & Overall Supervisor– Dean Williams |
| | 1 Survey Captain - Nazim Berjes |
| | 1 Chain Saw Worker - Miguel Mendez |
| | 2 Field Workers - Javier Manzanero
Luis Jimenez |
| Team 2 | 1 Survey Technician - Walter Calix |

	1	Survey Captain -	Samuel Garcia
	1	Chain Saw Worker -	Gian Landero
	3	Field Workers -	Miguel Escobar Cesar Hob
Team 3	1	Survey Technician -	Jose Luis Cunil
	1	Survey Captain -	Isais Mendez
	1	Chain Saw Expert -	Ronai Montero
	2	Field Workers -	Lucas Mendez Luis Frutos
	1	Cook (to serve all 3 teams) -	Domingo Martinez

Total Estimated Cost of Survey Sapodilla **\$20,000.00**

DELIVERABLES

Survey Report	\$ 5,000.00
Cadastral Maps both in hardcopy and CAD format	\$ 5,000.00
Compilation Map of Survey in hardcopy CAD format	\$ 3,000.00
Field notes \$ Nil	

TOTAL ESTIMATES for survey of South Water & Sapodilla Cayes \$93,000.00

I THEREFORE OFFER \$93,000.00 FOR THE TASKS

DURATION

Two month seems adequate for the task. However, it would be considerate if the task was started at the beginning of September and be concluded by or before the end of October.

An early start avoids the change of weather we anticipate in November.

Sincerely,

A handwritten signature in blue ink, appearing to read 'H.A. Fairweather', with a horizontal line extending from the end of the name.

H.A. Fairweather

Lic. Land Surveyor Belize

Placement of Markers and Labelling



Diagram #1

Monument Transverse Section

MAJOR (\triangle):- 4" PVC Pipe with 1/4" thick walls. Set at opposite ends of the island

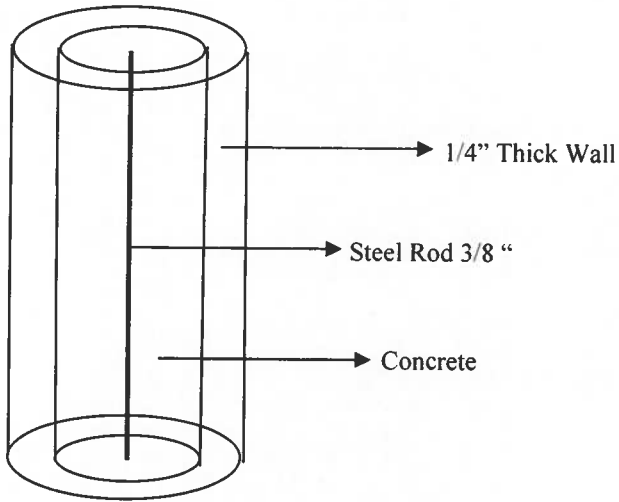

MINOR (\circ):- 2 1/2" Diameter PVC Pipe with 3/8" steel rod

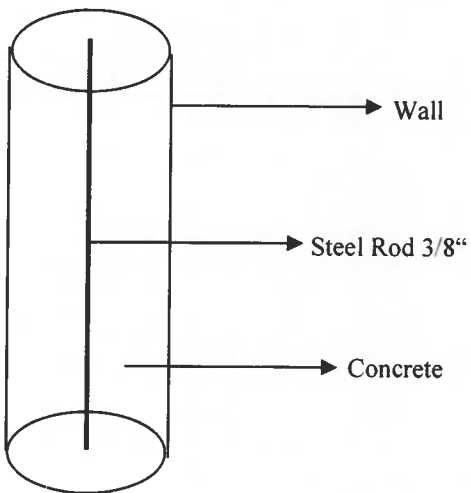

Universität Bonn Brunsbü.

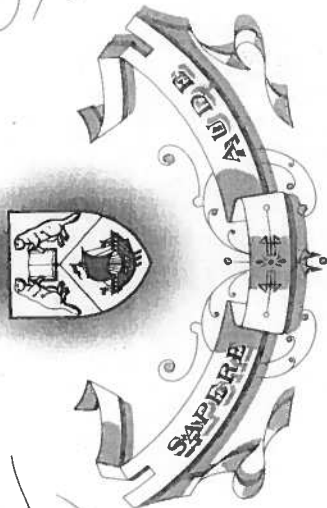

Comitiis habitis Septimo Decimo Die Maii
Anno Domini Millesimo Nongentesimo Septuagesimo Tertio

Henry Alexis Fairweather

*Omnibus muneribus quae statutis postulanti rite peractis, auctoritate
qua Praeses ac Collegium Gubernatorum funguntur,
Baccalaureus in Scientia in Re Ingentaria
creatus et pronuntiatus est, et in omnia jura, privilegia,
insignia admissus.*

In cujus rei testimonium, Nos hactec literis,

Universitatis sigillo munitis, manum apposuimus.



Commentarius
Præses

Ledi G. Jaeger

De Blue

Præses

Librarius



LICENCE TO LAND SURVEYOR

The Land Surveyor's Ordinance 1977 (Section 7)

Whereas the Land Surveyors' Board established under the above mentioned Ordinance is satisfied that Mr. **HENRY A. FAIRWEATHER**.....

of **BELIZE CITY**..... by virtue of **B. Sc. SURVEYING ENGINEERING**.....
..... is duly qualified to practise as a Land Surveyor, and has recommended the grant to him of a licence to practise as such surveyor;

NOW therefore, I **EDUARDO JUAN**....., Minister responsible for survey matters in pursuance of the provisions of the above mentioned Ordinance hereby authorize the said **HENRY A. FAIRWEATHER**..... to practise as a Land Surveyor in Belize.

DATED this **9th** day of **JANUARY**..... 19**96**.

Minister responsible for survey matters.

BRADLEY STREET, SANTA ELENA, P.O. BOX 172 SAN IGNACIO/SANTA ELENA TOWN,
TEL: 601-9145 , EMAIL: halexisf@gmail.com.

H. Alexis Fairweather - Resume

Triangulation.

1985 – 1988

PRINCIPAL SURVEYOR

**GEODETIC ASTRONOMY: BLACK'S METHOD FOR DETERMINATION OF ASTRONOMIC
AZIMUTH AND DEVIATION OF THE VERTICAL IN THE MERIDIAN (ξ) AND PRIME
VERTICAL (η)**

Preparation of daily 'Star Programme' before observation.
Complete reduction of previous night's observations. Compute
field checks for azimuth and deviation of the vertical. Observe
seven sets of four stars (fifth magnitude and greater) for two
nights, at both ends of selected Baselines in the chain of
triangles (see at 1982 - 1984).

Observed a total of 112 stars at each baseline, at altitude of 35°
for optimization of accuracy in azimuth and deviation of the
vertical. Each baseline required one day for preparation followed
by four nights of

observations and one day to travel to the next baseline.
Completed ninety baselines in two years.

Achieved accuracy in azimuth: $\pm (0.45'' - 0.35'')$.

Accuracy of deviation of the vertical: $\pm 1.00''$.

Preparation of contour map of 'Deviation of the Vertical'.

1987 – 1988

PRINCIPAL SURVEYOR

Determination of second order astronomic latitude and longitude (northern Empty
Quarter, near Qater).

First order Geodetic levelling (precision $\pm 0.02\text{mm std./1 km double run}$) , field
planning, execution

and computation for intermediate points. And adjustment of Misclosure.

SAUDI / IRAQI PIPELINE: Starts at northern boundary of Saudi Arabia with Iraqi
and joins Saudi 'East – West Pipeline' at Pump Station #2 , for transport of crude oil

BRADLEY STREET, SANTA ELENA, P.O. BOX 172 SAN IGNACIO/SANTA ELENA TOWN,
TEL: 601-9145 , EMAIL: halexisf@gmail.com.

H. Alexis Fairweather - Resume

to Port of Yanbu, Red Sea).

The pipeline is 400kms from start to join at Pump Station #2 (East - West Pipeline).
Planned and executed first order theodolite traverse (Wild T3 and Geodimetre 600)
supported

by GPS control monuments along pipeline. U.T.M. coordinates for pipeline were
derived from

traverse after adjustment to GPS traverse.

Wild T-3 theodolite, precision $\pm 0.2''$.

Geodimetre - Model 8, precision $\pm (6\text{mm} \pm 1 \text{ ppm})$.

1988 - 1989
SAUDI ARABIA

ARAMCO TECHNICAL INSTITUTE DAMMAM

PRINCIPAL SURVEYOR (Lecturer)

Prepared and taught survey mathematics to senior survey technicians.

Taught use and maintenance of survey instruments for measuring
angles and distances,

(Theodolite and Distance Metres). Proper procedures in note keeping.

Adjustment and calibration of Theodolite and Distance Metre.

1989- 1994
COMMISSION

JATCO SAUDI ARABIA AT THE ROYAL

SINAIYAH

FOR JUBAIL AND YANBU, AT YANBU, AL-

(RED SEA.)

1989
OFFICE ENGINEER

For Jatco Saudi Arabia at the 'Royal Commission' for Jubail and
Yanbu at Janbu Al

Sinaiyah.

BRADLEY STREET, SANTA ELENA, P.O. BOX 172 SAN IGNACIO/SANTA ELENA TOWN,
TEL: 601-9145 , EMAIL: halexisf@gmail.com.

H. Alexis Fairweather - Resume

Responsible for supervision of field personnel monitoring contractors works.

Production of engineering maps from field data: subdivision surveys; streets and lots.

Surveying utilities, roads, drains and production of related as built maps.

Small inshore hydrographic surveys and charts at the 'Industrial Port Of Yanbu'.

1990 – 1994

PROJECT MANAGER

Survey Consultant to the 'Royal Commission' for Jubail and Yanbu, at Yanbu Industrial City.

Administrated Yanbu Office: personnel, technical and field engineering activities at Yanbu Al Sinaiyah.

Consultative meeting with Royal Commission at weekly intervals.

STAFF OFFICE MECHANIC SHOP

FIELD

<u>One Office Engineer</u>	<u>Four Surveyor</u>	<u>One</u>
<u>Mechanic</u>		
<u>One Computer Specialist</u>	<u>Four Technicians</u>	<u>One</u>
<u>Helper</u>		
<u>Four Draughtsmen</u>	<u>Four Survey Workers</u>	

BRADLEY STREET, SANTA ELENA, P.O. BOX 172 SAN IGNACIO/SANTA ELENA TOWN,
TEL: 601-9145 , EMAIL: halexisf@gmail.com.

H. Alexis Fairweather - Resume

Deformation measurements on surface of slew bearing supports for half portal crane at quay side Port of Yanbu Port.
Required accuracy ($\pm 0.02\text{mm}$), it was achieved.

FAIRWEATHER TECHNICAL SERVICES BELIZE (FTS), (1994 - 2010)

1994- 2003

SURVEYOR AT FTS

FTS – Small private survey practice mainly serving ‘Tate and Lyle’ Sugar Co. as consultant.

(FTS establish in 1961 by H. C. Fairweather ARICS MRTPI. Deceased since October, 2002).

Cadastral Surveys: Subdivision Design and Surveys.

Engineering, Topographic, Roads and site surveys.

Surveyed the legal Boundary of ‘Five BLUES LAKE NATIONAL PARK’, approximately

18000 Acs.

Three dimensional EDM traverse from Dangriga Town along Melinda Road to valley road

in support of transect surveys across ‘North Stann Creek River’, at 1kms. intervals and at Joe Taylor Creek, 2kms upstream from the Sea, at Punta Gorda Town. Survey of east/west

profile across the middle of Punta Gorda Town. All of the above for Storm Surge Modelling.

Granted Licence to practice Land Surveying In Belize on 9 Jan.1996 .

BRADLEY STREET, SANTA ELENA, P.O. BOX 172 SAN IGNACIO/SANTA ELENA TOWN,
TEL: 601-9145 , EMAIL: halexisf@gmail.com.

H. Alexis Fairweather - Resume

2003 – 2004
and CAYO

FTS - CADASTRAL SURVEYS in TOLEDO

DISRICTS

LICENSED SURVEYOR

Started in September 2004, boundary survey for Sarstoon Temash Institute for Indeginous Management (SATIIM) – between the Temash and Sarstoon rivers.

2004 – 2005

Completed Sarstoon Temash boundary survey in April 2005. (A Forest Reserve of forty
-one thousand acres with linear boundary of 45 kms).
Re-survey of Gomez Estate (760acres) – 4 miles from Punta Gorda Town.

2005 – 2007

Commenced survey of Paynes Creek National (Toledo District).
Completed in 2007.
The area surveyed was forty-two thousand acres. Total linear boundary was forty-seven kilometres.

2008 June to 2009 June

Employed by the Government of Belize, Principal Surveyor (one year contract).

BRADLEY STREET, SANTA ELENA, P.O. BOX 172 SAN IGNACIO/SANTA ELENA TOWN,
TEL: 601-9145 , EMAIL: halexisf@gmail.com.

H. Alexis Fairweather - Resume

HENRY ALEXIS FAIRWEATHER (STUDENT) : SUMMER ATTACHMENTS WHILE AT UNIVERSITY OF

NEW BRUNSWICK, FREDERICTON NEW BRUNSWICK, CANADA.

:

1972 Selection of pass and tie points for 'Aerial Survey of the Island of Prince Edward'

For 'Block Aerial Triangulation' for the Prince Edward island Mapping Project.

University of New Brunswick, Canada.

1971: Made field observations with Wild N3 over set course and Bench Marks.

Computed orthometric heights for Bench Marks at 'First Order, Class 1 - accuracy'.

Required to test prototype Laser Level developed at the University.

Calibration of Wild A – 10 stereo – plotter (with precise calibration plate).

Development of real time programme for 'Wang Desk Top Computer' interfaced with Wild

A-10 plotter (research project) for computation of volumes, areas, length of space lines

and curves in real time. It was successful; but shortly overtaken

BRADLEY STREET,SANTA ELENA, P.O.BOX 172 SAN IGNACIO/SANTA ELENA TOWN,
TEL: 601-9145 , EMAIL: halaxisf@gmail.com.

H. Alexis Fairweather - Resume

by new and unpredicted developments in computer software.

1970: Attached to the Federal Hydrographic Department of Canada at
Bedford Institute Of

Oceanography Halifax Nova Scotia:

One Month in the Great Lakes

Revision work in Parry Sound. Recovery of underwater power lines,
hazards to navigation,

inspect light houses and range lights in Georgian Bay and northern
Lake Huran up to

Killarney.

Travelled to and through Sault Saint Marie Locks into Lake Superior on
to Michipicoten

at Lake Superior, where we did hydrographic survey for harbor at
Michicpicoten.

Two months in the gulf of Saint Lawrence

BRADLEY STREET,SANTA ELENA, P.O.BOX 172 SAN IGNACIO/SANTA ELENA TOWN,
TEL: 601-9145 , EMAIL: halexisf@gmail.com.

H. Alexis Fairweather - Resume

[School Name]

[City, ST]

[Degree obtained]

- [Special award, accomplishment, or degree minor]

Interes

ts [Briefly list interests that may pertain to the job you want]

Refere

nces References are available on request.

BRADLEY STREET, SANTA ELENA, P.O. BOX 172 SAN IGNACIO/SANTA ELENA TOWN,
TEL: 601-9145 , EMAIL: halaxisf@gmail.com.

H. Alexis Fairweather - Resume

June 2009 – 2011

Minor surveys registry work and small consultancies.

2012 – 2013

FAIRWEATHER TECHNIAL SERVICES

Cadastral survey of Jaguar Corridor.
Delineation of four linear boundaries 15 kms.

March to September 2012

HYDROPLAN CONSULTANCY.

TOPOGRAPHICAL
SPECIALIST

Project No. BL-L1013.

Flood Mitigation Infrastructure (BL – L1013).

Civil Works – Belama 4.

Determine Mean Sea Level height from IAGS Monument at Belize
Technical College, Belize City to large bolt on water line at approach to
Haulover Bridge.

Double Run (15.5 kms.), First Order, Class Two.

Centre-Line and cross-sections survey of roads 275 cross-sections at
25 metre intervals.

Bill Lindo and Maheia Canals 125 cross-sections.

Computed Digital Elevation Model (computed DEM in Excel Sheet).

BRADLEY STREET, SANTA ELENA, P.O. BOX 172 SAN IGNACIO/SANTA ELENA TOWN,
TEL: 601-9145 , EMAIL: halexisf@gmail.com.

H. Alexis Fairweather - Resume

Objective

Application of 'Advance Surveying Engineering Techniques' to

- 1) Hydrographic surveys,
- 2) Civil Engineering Works (Dams, Highways, Roads, Bridges, Drains).
- 3) Surveying and Mapping of: Agricultural Projects, Cadastral and Topographical Surveys, Geodetic Surveys.
- 4) Lidar Surveys: Planning, Initiation and Field Support.

Granted "Bachelor of Science Surveying Engineering (B.Sc. Sur. Eng.) in 1973 from University of New Brunswick, Canada.

Experience

- 1973 - 1979 Land and Survey Department
Government of Belize
- SURVEYOR
- Responsibility for Cadastral surveys in Belize City and Belize District. And supervision of
 - four field parties in this region.
 - Prepared and taught land surveying courses for Assistant Surveyors and also for Survey Technicians at the end of each year.
 -

1977 - 1978 LAND AND SURVEY
DEPARTMENT GOVERNMENT
OF BELIZE. [City, ST]

SURVEYOR

Planning and subdivision design for extension of towns and villages. Retracement Surveys of Large Estates and Engineering surveys for agricultural projects (e.g. site selection and

BRADLEY STREET, SANTA ELENA, P.O. BOX 172 SAN IGNACIO/SANTA ELENA TOWN,
TEL: 601-9145 , EMAIL: halexisf@gmail.com.

H. Alexis Fairweather - Resume

relocation of
'Rice Mill' from Belize City to Big Falls, Toledo District.

▪

LAND AND SURVEY
DEPARTMENT GOVERNMENT
OF BELIZE.

1978 - 1979

[City, ST]

SURVEYOR

Responsibility for control surveys in Belize: densification of second order

control.

Placement of new monuments between established higher order monuments.

Computation of UTM Coordinates (Zone 16, Belize Datum) for new monuments, from field data (angles and distance).

▪

LAND AND SURVEY
DEPARTMENT GOVERNMENT
OF BELIZE.

1979

[City, ST]

ACTING PRINCIPAL SURVEYOR

▪ Appointed while on leave in Britain. Could not return to take up the position consequence of illness in the family (death of my wife's father followed shortly after by hospitalization of her mother, who was in needed of care).

▪

1980

DHARAN, SAUDI ARABIA

1980 – mid 1980

Al Mesaha Desert Enterprises, Saudi Arabian Company.

PRINCIPAL SURVEYOR

*At the 'Industrial City of JUBAIL' on the Persian Gulf, for Bechtel Cooperation, of the United States of America: layout of twenty kilometres of high speed expressway around the

Industrial site.

*Set out all transition curves, circular curves and super elevations for expressway.

BRADLEY STREET, SANTA ELENA, P.O. BOX 172 SAN IGNACIO/SANTA ELENA TOWN,
TEL: 601-9145 , EMAIL: halexisf@gmail.com.

H. Alexis Fairweather - Resume

1980 – 1989
TO

SECONDED FROM AL MESAHA DESERT ENTERPRISES
SURVEYING AND MAPPING ARABIAN OIL COMPANY
(ARAMCO: SAUDI ARABIA).

1980 - 1981
PRINCIPAL SURVEYOR

Aerial Photogrammetry: field identification of pass points for large and small scale photogrammetry.
Surveyed for U.T.M. coordinates and elevation by spirit leveling of pass points.
Reduction of field data.

1982 – 1984
PRINCIPAL SURVEYOR

First Order Geodetic Network (Planning and execution of all field work, reduction of observed Data) and computational checks.
Planning geodetic surveys to cover many Oil Fields in the Eastern Province of Saudi Arabia, by trilateration and triangulation.
Connecting the separate OIL Fields , by trilateration and triangulation to form a single Chain.

PERSIAN GULF SAFANIYIAH OFFSHORE GAS FIELD IN THE

Located the position of all platforms in the Safaniyiah Gas Field in the Persian Gulf.
Geodetic Levelling: over the 'Oil Field Surveys Eastern Province', Saudi Arabia, ending at the Iraqi/Saudi and Kuwaiti/Saudi International Borders.

A NOTE: to achieve the necessary accuracy with short sides, consequence of limited sighting

Distances and avoiding the use of survey towers, necessitated the measurement of all elements of the Triangles i.e. three sides and three angles, Trilateration and

SOUTH WATER CAYE MARINE RESERVE
STANN CREEK DISTRICT



1:200,000

Source: Esri, DigitalGlobe, GeoEye, Earthstar, Geographics, CNES/Airbus DS, USA, USGS, AeroGRID, IGN, and the GIS User Community

South Water Caye Marine Reserve:

There is a total of 82 Cayes → 28

A total of 132 Survey Plans → 22
50 days

Entry No. 405 Reg. No. 2

Entry No. 520 Reg. No. 5

Entry No. 834 Reg. No. 8

Entry No. 924 Reg. No. 2

Entry No. 1003 Reg. No. 8

Entry No. 1181 Reg. No. 12

Entry No. 1685 Reg. No. 4

Entry No. 2409 Reg. No. 8

Entry No. 2455 Reg. No. 8

Entry No. 2704 Reg. No. 14

Entry No. 3002 Reg. No. 11

Entry No. 3334 Reg. No. 14

Entry No. 3378 Reg. No. 4

Entry No. 3414 Reg. No. 15

Entry No. 3456 Reg. No. 4

Entry No. 3502 Reg. No. 14

Entry No. 3510 Reg. No. 14

Entry No. 3839 Reg. No. 4

Entry No. 3870 Reg. No. 2

Entry No. 3979 Reg. No. 4

Entry No. 4024 Reg. No. 2

Entry No. 4082 Reg. No. 7

Entry No. 4310 Reg. No. 15

Entry No. 4455 Reg. No. 4

Entry No. 4634 Reg. No. 4

Entry No. 4962 Reg. No. 7

Entry No. 5210 Reg. No. 7
Entry No. 5482 Reg. No. 2
Entry No. 5713 Reg. No. 4
Entry No. 5995 Reg. No. 4
Entry No. 6188 Reg. No. 25
Entry No. 3306 Reg. No. 4
Entry No. 6441 Reg. No. 7
Entry No. 6488 Reg. No. 4
Entry No. 6525 Reg. No. 7
Entry No. 5529 Reg. No. 26
Entry No. 6533 Reg. No. 4
Entry No. 6577 Reg. No. 4
Entry No. 6615 Reg. No. 4
Entry No. 6676 Reg. No. 4
Entry No. 6677 Reg. No. 4
Entry No. 6760 Reg. No. 22
Entry No. 6808 Reg. No. 26
Entry No. 6868 Reg. No. 11
Entry No. 7005 Reg. No. 4
Entry No. 7067 Reg. No. 22
Entry No. 7072 Reg. No. 4
Entry No. 7087 Reg. No. 7
Entry No. 7310 Reg. No. 4
Entry No. 7928 Reg. No. 7
Entry No. 7945 Reg. No. 29
Entry No. 8121 Reg. No. 7
Entry No. 8154 Reg. No. 7
Entry No. 8261 Reg. No. 29
Entry No. 8285 Reg. No. 7
Entry No. 8324 Reg. No. 29

Entry No. 8364 Reg. No. 7
Entry No. 8381 Reg. No. 7
Entry No. 8438 Reg. No. 7
Entry No. 8490 Reg. No. 4
Entry No. 8662 Reg. No. 29
Entry No. 8712 Reg. No. 3
Entry No. 8733 Reg. No. 4
Entry No. 8747 Reg. No. 7
Entry No. 8757 Reg. No. 7
Entry No. 8768 Reg. No. 29
Entry No. 8794 Reg. No. 7
Entry No. 8798 Reg. No. 29
Entry No. 8799 Reg. No. 29
Entry No. 8830 Reg. No. 29
Entry No. 8887 Reg. No. 7
Entry No. 8889 Reg. No. 7
Entry No. 8894
Entry No. 8925 Reg. No. 7
Entry No. 8968 Reg. No. 29
Entry No. 8988 Reg. No. 25
Entry No. 9010 Reg. No. 18
Entry No. 9050 Reg. No. 29
Entry No. 9051 Reg. No. 29
Entry No. 9052 Reg. No. 29
Entry No. 9074 Reg. No. 18
Entry No. 9097 Reg. No. 3
Entry No. 9150 Reg. No. 7
Entry No. 9191 Reg. No. 18
Entry No. 9192
Entry No. 9204 Reg. No. 7

Entry No. 9232 Reg. No. 29
Entry No. 9257 Reg. No. 18
Entry No. 9293 Reg. No. 29
Entry No. 9324 Reg. No. 29
Entry No. 9355 Reg. No. 29
Entry No. 9376 Reg. No. 18
Entry No. 9386 Reg. No. 7
Entry No. 9408 Reg. No. 29
Entry No. 9439 Reg. No. 18
Entry No. 9501 Reg. No. 29
Entry No. 9600 Reg. No. 29
Entry No. 9868 Reg. No. 29
Entry No. 9890 Reg. No. 18
Entry No. 9897 Reg. No. 15
Entry No. 9938 Reg. No. 7
Entry No. 10159 Reg. No. 29
Entry No. 10485 Reg. No. 29
Entry No. 10563 Reg. No. 7
Entry No. 10616 Reg. No. 7
Entry No. 10722 Reg. No. 29
Entry No. 10744 Reg. No. 18
Entry No. 10791 Reg. No. 18
Entry No. 10821 Reg. No. 29
Entry No. 10882 Reg. No. 28
Entry No. 10927 Reg. No. 29
Entry No. 10954 Reg. No. 15
Entry No. 10992 Reg. No. 29
Entry No. 11035 Reg. No. 7
Entry No. 11037 Reg. No. 29
Entry No. 11087 Reg. No. 28

Entry No. 11159 Reg. No. 25

Entry No. 11204 Reg. No. 28

Entry No. 11204 Reg. No. 28

Entry No. 11620 Reg. No. 29

Entry No. 11623 Reg. No. 29

Entry No. 12381 Reg. No. 22

Entry No. 13226 Reg. No. 7

Entry No. 13525 Reg. No. 7

Entry No. 13713 Reg. No. 29

Entry No. 14392 Reg. No. 7

Entry No. 15625 Reg. No. 7

Entry No. 15904 Reg. No. 7

Entry No. 16082 Reg. No. 3

Entry No.17036 Reg. No. 25

Plan 1979

Plan No. 2135

SAPODILLA CAYE MARINE RESERVE
STANN CREEK DISTRICT

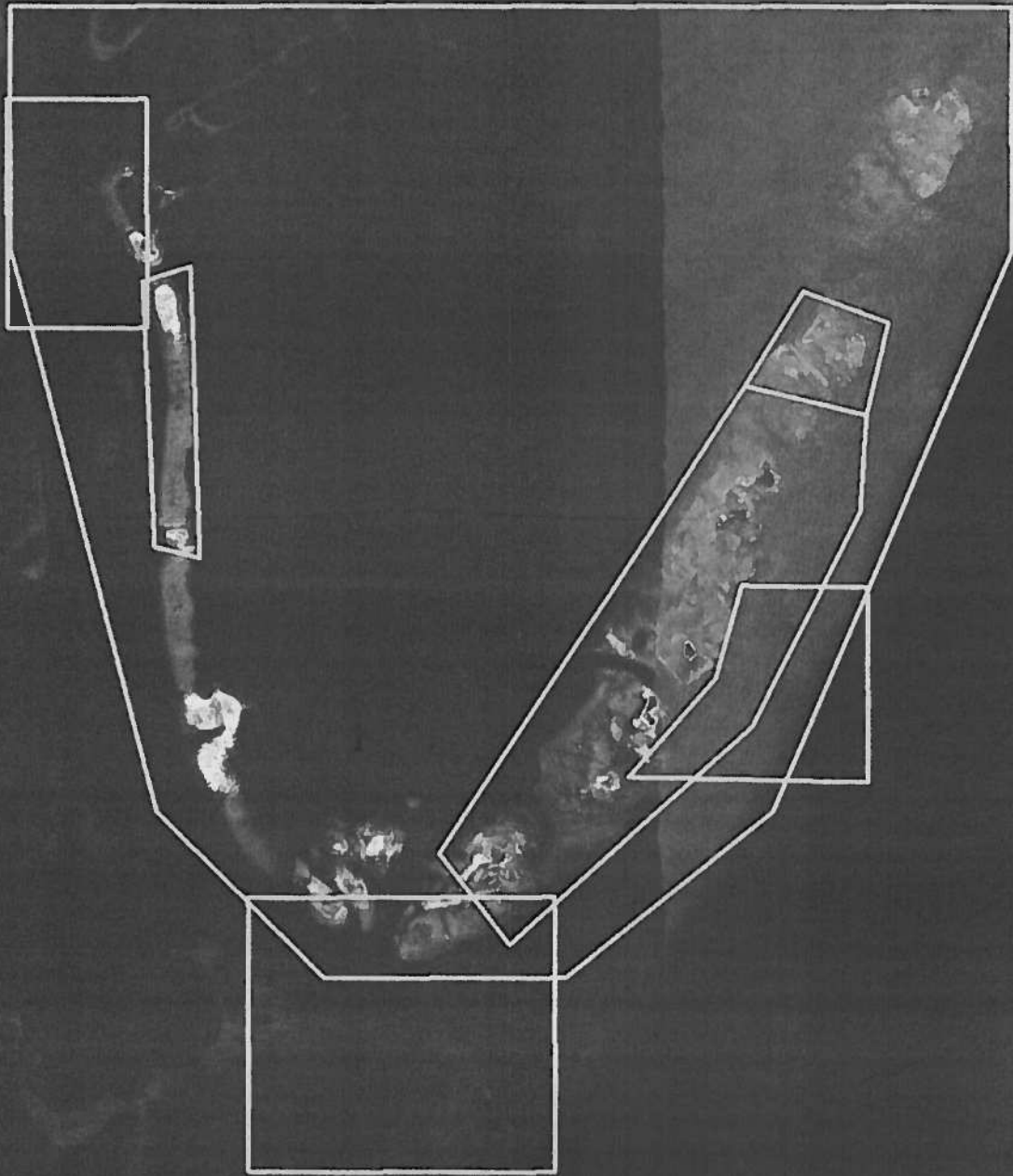

1:100,000

Source: Esri, DigitalGlobe, GeoEye, Earthstar Geographics, CNES/Airbus DS, USDA, USGS, AeroGRID, IGN, and the GIS User Community

SapodillaCaye Marine Reserve:

There is a total of 10 Cayes - 4 done

A total of 12 Survey Plans → 2 done
6 done

Entry 4013, Reg. No. 7

Entry No. 11646, Reg. No. 28

Entry No. 2900, Reg. No. 4

Entry No. 2428, Reg. No. 4

Entry No. 8652, Reg. No. 16

Entry No. 3398, Reg. No. 14

Entry No. 6826, Reg. No. 15

Entry No. 4044, Reg. No. 16

Entry No. 8420, Reg. No. 15

Entry No. 3975, Reg. No. 15

Entry No. 11163, Reg. No. 25

Plan No. 2025

BELIZE

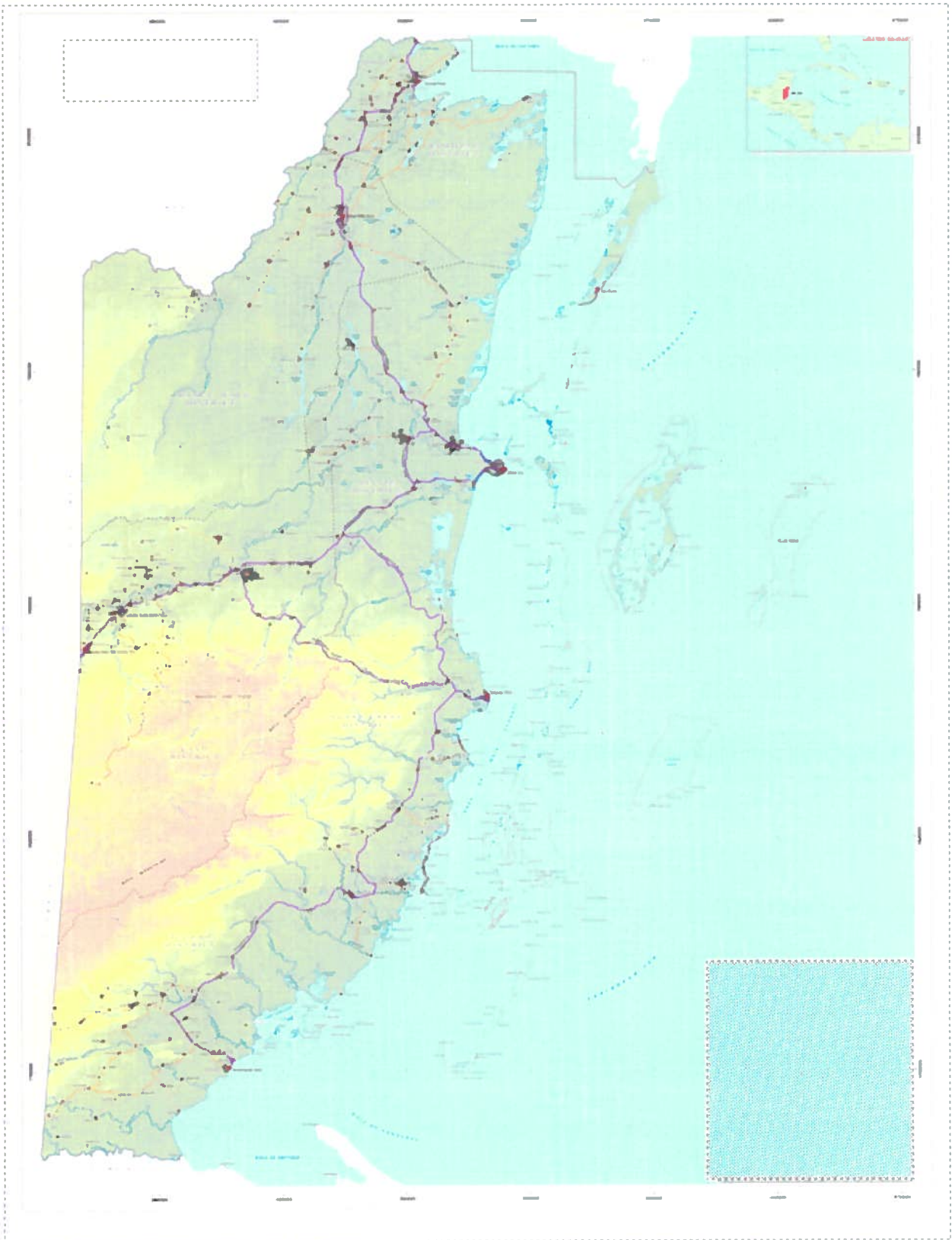

Date:- August 2018

C O N T R A C T

THIS CONTRACT is made this day of , 2018 **BETWEEN** the **WORLD WILDLIFE FUND** of 1154 Sunrise Drive, Unit 104, Belize City, Belize (hereinafter called “the Client”) of the one part and **HENRY ALEXIS FAIRWEATHER**, of Bradley Street, Santa Elena Town, Cayo District, Belize (hereinafter called the “Contractor”) of the other part.

WHEREAS the client is desirous of surveying the lands generally described in the Schedule hereto and has appointed the aforementioned Contractor to carry out the works described herein;

AND WHEREAS the Contractor is willing and able to undertake the survey of the said lands upon the terms and conditions set out herein;

NOW THEREFORE the Parties hereto agree as follows:

1. The Contractor shall commence immediately upon the signing of this Contract a survey of the lands described in the Schedule hereto, which Schedule forms an integral part of this Contract, and shall complete the survey within the period of eight (8) weeks from the date of the signing hereof. Provided that completion beyond the specified period is **NOT** the cause of the Contractor. The plan of the survey shall be submitted and received at the Lands & Survey Department of the Government of Belize for authentication and registration within four (4) weeks of the completion of the survey, in accordance with the practice and procedures established

under the Land Surveyors Act, Chapter 187, Substantive Laws of Belize, R.E. 2011 and the Land Survey Regulations, Chapter 187, Subsidiary Laws of Belize, R.E. 2003, as may be amended.

2. Where the Contractor fails to submit the Survey Plan for authentication and registration within the time specified in paragraph one (1) above, without prejudice to any other rights to both parties under this Contract or under the laws, the Contractor shall become liable to pay a penalty in the sum of Belize Currency **\$25.00** per week and the Client may deduct the total sum due in penalties by the Contractor from any compensation which may be outstanding to the Contractor under this Contract.
3. The Contractor shall diligently perform all and singular his obligations under this Contract and with the utmost dispatch. Without prejudice to the generality of the foregoing, the method of survey and accuracy required; the spacing and type of marks that shall be used; the plotting scales and the method of presentation of the plan; and all other aspects of the survey shall be in accordance with the Land Surveyors Act and Land Survey Regulations of the Laws of Belize, and the Contractor shall notify the Client in writing of any persons or development occupying the lands being surveyed under this Contract.
4. The Client shall compensate the Contractor the sum of Belize Currency **Ninety Three Thousand Dollars (\$93,000.00)** which shall be the total remuneration payable by the Client to the Contractor under this Contract:

Provided that if the survey do not come to the contemplated distance as specified in the Schedule hereto, the above-mentioned sum shall be adjusted proportionately by such amount as agreed in writing and signed by the two parties hereto, and such amount shall for all intents and purposes be originally set out herein.
5. Payment shall be made directly to the Contractor, in Belize currency. The compensation to the Contractor shall be made as follows;

- a) The Client will make a first payment hereinafter referred to as mobilization payment of Belize Currency **Thirty Seven Thousand Two Hundred Dollars and Zero Cents (\$37,200.00)** representing forty percent (40%) of the sum specified in paragraph four (4) above upon signing of this Contact.
- b) Thereafter the Client shall make payment as follows:
 - i) Four equal payments of Belize Currency **Eleven Thousand Six Hundred Twenty Dollars and Zero Cents (\$11,625.00)** every fortnight with the first of the four equal payment being two weeks after the mobilization payment.
 - ii) A retention representing ten per centum (10%) of the Contract Total Sum and equivalent to Belize Currency **Nine Thousand Three Hundred Dollars and Zero Cents (\$9,300.00)** shall be the last and final payment to the Contractor will be payable immediately upon completion of authentication and registration of the Survey Plan by the Lands & Survey Department of the Government of Belize.

6. The Client may, without prejudice to any other right of both parties under the law, immediately by notice in writing, terminate this Contract if:
- a) the Contractor is not performing his obligations under this Contract with the speed and accuracy required of him under this Contract;
 - b) any bankruptcy petition is presented in respect of the Contractor or if the Contractor commits any act of bankruptcy or shall become bankrupt or make any composition or arrangement with his creditors or suffer any execution against his property; or
 - c) the Contractor suspends performance of his obligations under this Contract for any reason of his own doings but not doings of The State or mother-nature to include but not limited to war, state of emergency, excessive rain, flood, tropical storm, hurricane, earthquake, tsunami and in the Client's opinion, the Contractor will

be unable to complete performance of his obligations under and in accordance with this Contract.

7. In the event of any termination the Contractor shall only be entitled to receive payment on a **QUANTUM MERUIT BASIS** and the Client may through its employees or a third-party licensed surveyor carry out the survey and may withhold from any monies payable to the Contractor upon termination on a **quantum meruit basis** any cost incurred in conducting the survey in excess of that which would have been payable to the Contractor under this Contract.
8. The parties shall resolve any dispute in relation to this Contract by way of negotiation and any dispute which the parties cannot resolve by themselves shall be resolved by way of third-party mediator to be agreed to by the parties and chosen from the Supreme Court Roster of Mediators. Any dispute which cannot be resolved by mediation shall be resolved by binding arbitration to be governed by the Arbitration Act, Chapter 69, Substantive Laws of Belize R.E. 2011 as may be amended.
9. The provisions of this Contract may be amended by agreement between the parties hereto. No amendment shall be valid unless it is in writing and signed by the parties hereto.
10. This Contract shall be governed by the Laws of Belize.

SCHEDULE

Survey of National Lands within the South Water and Sapodilla Cayes Marine Reserves situated within Belize's national territorial sea;

- 1) To determine available lands within the South Water Caye and Sapodilla Caye Marine Reserves by field inspection and appropriate Land Survey methods, and;**
- 2) Survey, un-surveyed Lands in the reserves in the areas of substantial mangrove coverage.**

See appendix "A" attached hereto.

BELIZE:

**ENVIRONMENTAL IMPACT ASSESSMENT (AMENDMENT)
REGULATIONS, 2019**

ARRANGEMENT OF REGULATIONS

1. Citation.
2. Substitution of a term.
[REDACTED]
4. Amendment of regulation 19.
[REDACTED]
[REDACTED]
7. Amendment of regulation 24.
[REDACTED]
9. Amendment of regulation 26.
[REDACTED]
11. Amendment of Schedule I.
[REDACTED]
13. Amendment of Schedule III.

BELIZE:

STATUTORY INSTRUMENT

NO. OF 2019

for

REGULATIONS made by the Minister responsible for the environment in exercise of the powers conferred upon him by sections 6, 7, 21 and 44 of the Environmental Protection Act, Chapter 328 of the Substantive Laws of Belize, Revised Edition 2011, and all other powers thereunto him enabling.

(Gazetted, 2019)

Citation.

1. These Regulations may be cited as the

**ENVIRONMENTAL IMPACT ASSESSMENT (AMENDMENT)
REGULATIONS, 2019**

S.I. 107 of 1995
24 of 2007,

and shall be read and construed as one with the Environmental Impact Assessment Regulations 1995, which, as amended, are hereinafter referred to as the principal Regulations.

Substitution of a
term.

2. [REDACTED]

[REDACTED]

3. [REDACTED]

Amendment of
regulation 19.

4. Regulation 19 of the principal Regulations is amended by repealing paragraph *(h)* and substituting the following—

“(h) A description of the likely significant effects, direct and indirect, of the development on the environment, explained by reference to its possible impact on–

- (i) human beings;
- (ii) flora;
- (iii) fauna;
- (iv) soil;
- (v) water;
- (vi) air;
- (vii) climate;
- (viii) material assets, including the natural heritage and landscape;
- (ix) natural resources;
- (x) the ecological balance;
- (xi) the Outstanding Universal Values ascribed under the World Heritage Site Designation to the area under development; and
- (xii) any other environmental factors which need to be taken into account.”.

5. [REDACTED]

[REDACTED]

[REDACTED]

[REDACTED]

6. [REDACTED]

[REDACTED]

[REDACTED]

[REDACTED]

[REDACTED]

[REDACTED]

[REDACTED]

[REDACTED]

[REDACTED]

[REDACTED]

[REDACTED]

Amendment of regulation 24.

7. Regulation 24 of the principal Regulations is amended—

- (a) [REDACTED]
- (b) in sub-regulation (2)(a) by inserting the words “including Outstanding Universal Values ascribed to the area under a World Heritage Site designation,” immediately after the words “the nature of the geographical area”.

[REDACTED]

8. [REDACTED]

[REDACTED]

[REDACTED]

[REDACTED]

[REDACTED]

[REDACTED]

[Redacted]

[Redacted]

(2)

[Redacted]

[Redacted]

[Redacted]

[Redacted]

[Redacted]

[Redacted]

[Redacted]

[Redacted]

[Redacted]

[Redacted]

[Redacted]

[Redacted]

[Redacted]

[Redacted]

[Redacted]

[Redacted]

[Redacted]

[Redacted]

[Redacted]

[Redacted]

[Redacted]

[Redacted]

[REDACTED]

[REDACTED]

[REDACTED]

[REDACTED]

[REDACTED]

[REDACTED]

[REDACTED]

[REDACTED]

[REDACTED]

[REDACTED]

Amendment of regulation 26.

- 9.** Regulation 26(2) of the principal Regulations is amended—
- (a) in paragraph (d), by deleting the word “and”;
 - (b) in paragraph (e), by deleting the full stop and substituting a semi colon; and
 - (c) by inserting the following new paragraph—
 - “(f) the proposed net benefit to the local economy, impact on local communities, and any conflicts with any existing natural resource management plans or programmes in the area.”.

[REDACTED]

- 10.** [REDACTED]
- [REDACTED]
- [REDACTED]

[Redacted text block]

11. Schedule I of the principal Regulations is amended by—

Amendment of Schedule I.

[Redacted text block]

(c) inserting the words “or World Heritage Site” after the words “protected area” in item 14(l).

12.

[Redacted text block]

Environmental Protection

Amendment of
Schedule III.

- 13.** Schedule III of the principal Regulation is amended—
- (a) in item 1, by inserting the words “or World Heritage Site” after the word “island”; and
 - (b) in item 3 by inserting the following new paragraph—
“(d) World Heritage Sites.”.

MADE by the Minister responsible for environment, this day of
, 2019.

Minister of Agriculture, Fisheries, Forestry,
the Environment, Sustainable Development
and Immigration
(Minister responsible for environment)